

# Security Services Newsletter

volume 1 issue 5

30/07/2010

We aim to ensure that on the issue of security and safety, as with any other serious business issue, our house is very much in order. This is only achievable by working in collaboration with our security staff.”

London projects or those that are situated in the city present some interesting challenges for a security provider. These challenges relate to three key security issues and demonstrate how security solutions on the ground can be tailored to match very specific corporate needs - needs that are satisfied through a healthy, collaborative approach to security provision.

The first security issue is location. The projects can be located on busy high streets or located in a predominantly residential area with no clear perimeter.

The second issue relates to the size of the projects. The projects can have in excess of 500 workers, as a result the security team must ensure they are operating efficiently to ensure all activity is monitored on site. This also presents a distinct challenge in managing access to the building by workers and, visitors.

Security personnel are required to manage the access areas and ensure that fire exits are kept clear.

Finally, there are a number of frequent events and deliveries, each of which involves a plethora of contractors and site visitors. It all adds up to a complex mix of issues and challenges. “Over the last few years the entire ethos of Dhesi Security has undergone a positive development,” explains Sammy, supervision of Shard security at Dhesi. “This is evident in the changes in security equipment and procedure. Recent improvements have included full-height turnstiles, ID cards, increased expenditure on security equipment and a higher degree of training and awareness for staff.

## Industry News

Scottish Justice Secretary Kenny MacAskill recently announced a clampdown on security firms winning Scottish Government contracts and declared a new policy of only allowing SIA approved contractors to carry out security work. The robustness of the approved contractor scheme has been further enhanced when the Home Office recently agreed an amendment to the 'fit and proper' criteria used when we consider a security suppliers application to become an approved contractor.

This is intended to help prevent approval of so-called 'phoenix' companies that have questionable origins. Now any person who was a sole trader, director or partner of a business/firm providing a security service which has been liquidated, placed in administration or receivership within the previous 12 months may not be considered as a 'fit and proper' person. Basic CCTV system

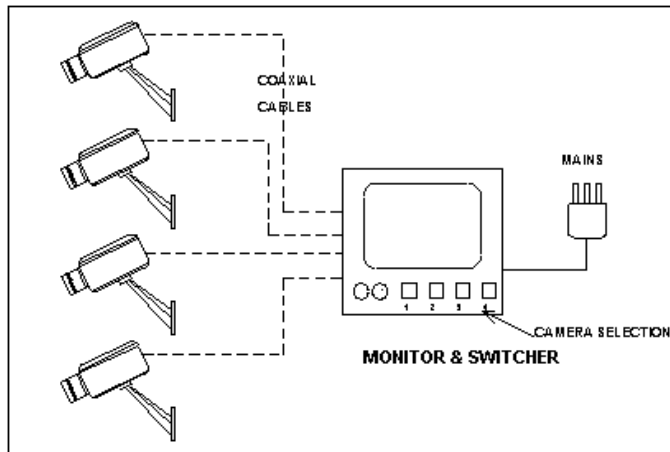

The Pinnacle



**For More Information Call:01474 833 388  
– [www.dhesiplc.com](http://www.dhesiplc.com)**

**Or Find us ON-LINE**